

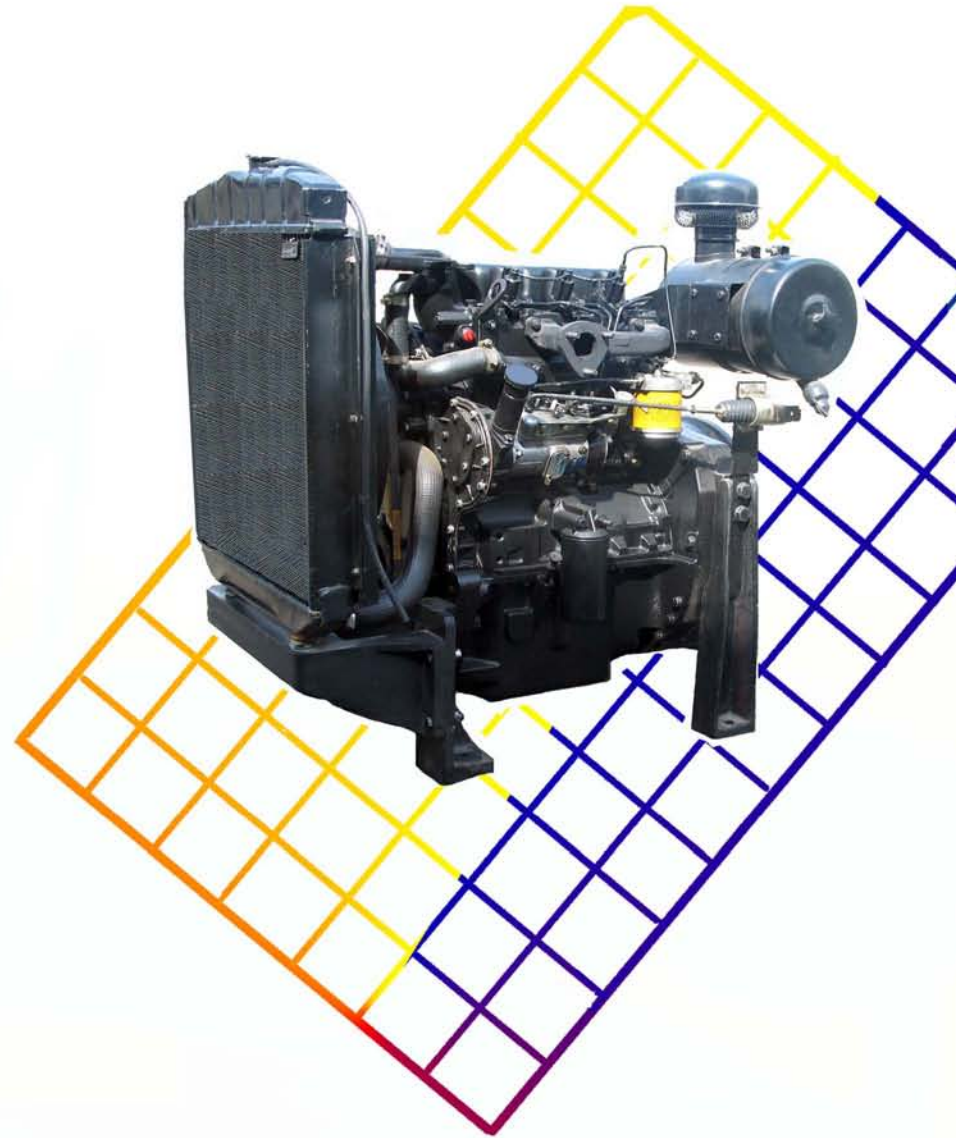

3.152G GENSET POWER



Performance

Engine speed rev/min	Type of operation	Typical generator output(net) kVA	Engine Power	
			kW	bhp
1500	Prime power	23.4	20.8	27.9
	Standby power	25.7	22.9	30.7



Standard specifications

Air filter:

Mounted air filter

Fuel system:

Rotary fuel injection pump
Mechanical governing
Single cartridge fuel filter and prefilter

Lubrication system:

Gray cast iron oil-sump with filler and dipstick
Spin-on full-flow oil filter

Cooling system:

Belt driven circulating pump
17" belt driven fan
Mounted radiator and pipework

Electrical equipment:

12 volt starter motor
12 volt 55 Amp alternator with DC output
Switch for oil pressure
12 volt shut down solenoid energized to run
Cold start aid

Flywheel and Housing:

High inertia flywheel to SAE J620 size 10/11 $\frac{1}{2}$
Cast iron SAE3 flywheel housing

Mountings:

Front mounting brackets

Optional equipment:

Coolant temperature gauge
Lubrication oil pressure gauge and sender
Heater/Starter switch
Flywheel and coupling suitable for double bearing alternators.
Rear mounting brackets

Fuel consumption litres / hour	
Power rating	1500 rev/min
Standby power	7.3
Prime power	4.9
75% of prime power	3.8
50% of prime power	2.8
25% of prime power	1.9

Basic technical data

Number of cylinder: 3
Cylinder arrangement: Vertical, in line
Cycle: 4 stroke
Induction system: naturally aspirated
Cubic capacity: 2.5 litres (152.7 cu-in)
Bore: 91.4 mm (3.6 in)
Stroke: 127 mm (5 in)
Compression ratio: 18.5:1
Direction of rotation: Clockwise viewed from front
Firing order: 1,3,2
Total lubrication system capacity: 6 litres
Coolant capacity (including radiator): 11 liters
Engine total weight (dry): 344 kg
Engine total weight (wet): 361 kg

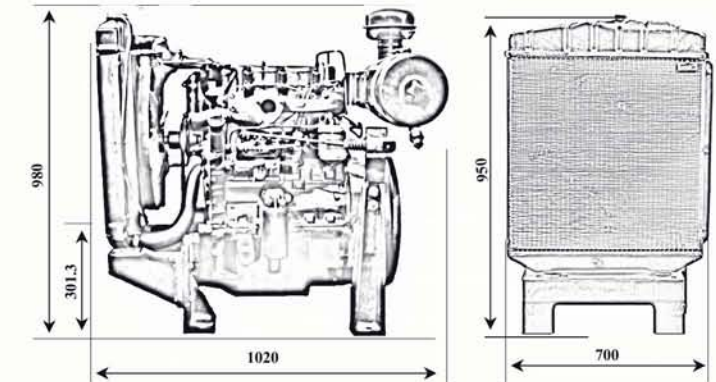

All dimensions are in mm

All ratings based on operation under ISO 3046 condition using typical fan sizes and drive ratios. For operation outside of these conditions please consult with Motorsazan company. Performance tolerance quoted by Motorsazan is $\pm 5\%$.
Electrical ratings assume a power factor of 0.8 and a generator efficiency of 90%.
Fuel specification: BS2869 Part 2 1998 Class A2 or ASTM D975 D2.
Rating Definitions:
Prime power: Power available at variable load in lieu of main power network. An overload of 10% is permitted for one hour in every twelve hours of operation.
Standby power: power available at variable load in the event of a main power network failure. No overload is permitted.

Factory address: P.O.BOX 51845-337 Tabriz-Iran
Tel: +98(411) 4248000
Fax: +98(411) 4245945-46
Website: www.motorsazan.ir
Email: mail@motorsazan.ir

- The illustrations may include some optional equipments.
- Motorsazan reserves the right to modify product specifications without prior notice.